



## Fabrication of a Hand Gesture Controlled Wheelchair

---

Aditya Shukla, Anand Jha, Shubham Pahal, Vishal Tyagi and  
Ajay Solanki

EasyChair preprints are intended for rapid dissemination of research results and are integrated with the rest of EasyChair.

April 3, 2024

## Fabrication of a Hand Gesture Controlled Wheelchair

Aditya SHUKLA<sup>1,a\*</sup>, Anand Kumar JHA<sup>2,b</sup>, Shubham PAHAL<sup>3,c</sup>, Vishal TYAGI<sup>4,d</sup>  
and Ajay SOLANKI<sup>5,e</sup>

<sup>1</sup>Delhi, INDIA, <sup>2</sup>Delhi, INDIA, <sup>3</sup>Delhi, INDIA, <sup>4</sup>Delhi, INDIA, <sup>5</sup>Delhi, INDIA

<sup>a</sup>shuklaaditya200@gmail.com, <sup>b</sup>anandku235@gmail.com, <sup>c</sup>shubhampahal007@gmail.com,  
<sup>d</sup>vishaltyagi1242@gmail.com, <sup>e</sup>ajay100lanki@rediffmail.com

**Keywords:** Arduino, Micro Controller, Accelerometer, Motor Controller, Drilling

**Abstract.** Hand-gesture controlled wheelchairs help in providing mobility and safety to individuals with physical disabilities or mobility impairments. In this paper, we have fabricated a wheelchair so that it can be controlled by hand-gestures and move smoothly in all 4 directions. The main focus of our research has been to drive down the cost of such a wheelchair as compared to the ones already available in the market to enable penurious people to afford it. An accelerometer sensor is fitted in the data glove to read the hand movements and the information is conveyed to an Arduino microcontroller using wires. The Arduino board controls the pair of DC wiper motors attached at the rear end on each wheel of the wheelchair. The proposed mechanism has demonstrated precise responsiveness to users' hand gestures during trials.

**Introduction.** Smart electric wheelchairs are emerging as a promising alternative to traditional wheelchairs, catering to the needs of the elderly and individuals with mobility impairments. These advanced devices offer enhanced manoeuvrability, navigational intelligence, and customizable control interfaces, making them ideal for indoor navigation and daily mobility tasks. The concept of smart wheelchairs has evolved significantly with numerous prototypes developed and some even commercialized. While conventional joystick controls have been predominant, they pose limitations for certain users, particularly the elderly and those with limited upper limb dexterity. As a result, researchers have explored alternative control methods such as hand gestures, voice recognition, head or chin control, and bio signal-based interfaces like EMG, EOG, or EEG. Hand gesture control, in particular, has garnered significant attention due to its intuitive nature and potential for precise control. Researchers have investigated various sensor fusion techniques to improve gesture recognition accuracy. Additionally, advancements in technology have led to innovations such as head orientation-controlled wheelchairs and voice recognition systems, catering to individuals with quadriplegia and other severe mobility impairments.

Notwithstanding the strides made in technological advancements, the persistent challenge lies in the mitigation of cost barriers associated with the adoption of these sophisticated wheelchair solutions. Hence, the focal point of this investigation revolves around the development of a hand-gesture controlled wheelchair that maintains a judicious balance between cost-effectiveness and adherence to strict standards of material quality and operational performance. To reduce the physical exertion associated with operating wheelchairs manually, researchers globally are exploring the integration of electromechanical systems. In addition to conventional joystick controls, emerging technologies in hand gesture sensing enable the translation of hand orientation into seamless wheelchair movements.

P. Upender et al. [1] proposed a Hand Gesture-Based Wheelchair with an Arduino-based control system and accelerometer for individuals with limited mobility, design addresses

challenges in mobility but acknowledges potential issues like power dependency and device failure. Tao Lu introduces a novel approach to intelligent wheelchair motion control through MEMS accelerometers and hand gesture recognition, employing Hidden Markov Models and Bayes method, demonstrating effectiveness in providing a more intuitive human interface for individuals with physical accessibility challenges [2]. An innovative MEMS-based wheelchair control system utilizing accelerometers for precise interpretation of hand gestures proposed by Prof. Vishal V. Pande N et al. [3]. Ramessur et al. [4] presented a hand-gesture-controlled robotic wheelchair using a MEMS sensor in a data glove, Zigbee communication, and detailed hardware components like ADXL345, Arduino Nano, and XBee, demonstrating accurate responses to various hand gestures and successful PID-based speed control for enhanced mobility. Goyal D and Saini S explored a gesture-based wheelchair control system using the MMA7660FC accelerometer, emphasizing its compact size, reduced complexity, and wireless capabilities, providing a comprehensive overview of features for different motions, processing speed, power consumption, and communication range [5]. Mahmood et al. [6] introduced a user-friendly Hand Gesture Controlled Automated Wheelchair with additional features like GPS tracking and emergency messaging. This cost-effective solution, operable with limited hand movement, complements Rusydi et al. [7] alternative method for electric wheelchair control using wrist rotation, emphasizing simplicity and accessibility for individuals with mobility challenges. Patankar et al. [8] emphasized on user-friendly construction and simplicity, including safety features like falling detection and automatic brakes. V Sundara Siva Kumar, G.Ramesh and P Nagesh [9] showed that the prevalence of automation in the realm of electronics is unparalleled, driving numerous technological advancements. Among these innovations, the MEMS ACCELEROMETER SENSOR stands out as a particularly significant development as it has a user-friendly design that elevates its importance above other technologies, making ACCELEROMETER SENSOR-based devices accessible to the general public. John, F., Shaju, J., Mathai, M. K., & Seby, M [10] demonstrated the impact of electronically controlled wheelchairs on the environment and society. Research conducted by Kannan Megalingam, Srikanth, and Raj [11] that integrating touch screen and Bluetooth technology enables individuals with disabilities to navigate by swiping across the screen. Additionally, in instances where individuals are unable to move their arms, a secondary user can assume control of movement, alleviating the need for manual wheelchair propulsion. G. Bourhis and K. Moumen demonstrate the availability of various guidance systems in the market designed to facilitate seamless navigation for individuals with physical disabilities. These systems exhibit notable competitiveness in revolutionizing conventional navigation methods [12].

**Methodology.** The present study endeavours to augment a conventional wheelchair through a meticulously orchestrated integration of mechanical and electronic adjustments, tailored to facilitate responsive control via hand gestures. Initially, the wheelchair underwent a series of mechanical adaptations to accommodate the incorporation of motorized components and Arduino-based devices. These mechanical enhancements encompassed precision welding procedures, shaft perforation, hub integration, and an array of complementary operations, each meticulously detailed in the subsequent section for comprehensive elucidation.

### **Mechanical Modifications.**

**Welding Of the Gears.** The wheelchair has to be embedded with the motor and gears in order to carry and move the weight. Motor automates the process of moving the wheelchair and the gears will help the wheelchair to carry the load. Gears were to be fitted in the axle of the wheels of wheelchair, consequently wheels were firstly de-assembled from the frame and then gear was

fitted into the axle of the wheelchair. For the welding process, submerged arc welding process was preferred over the others. The simple reason for this preference was the edge of oxidation protection provided by the SAW over the other process. Gears were arc welded into a metallic cylindrical structure whose outer diameter was equal to the inner of that of gear and the inner diameter was equal to the diameter of the axle, so that after welding, the complete modified gear structure could easily be fitted into the wheelchair. The final assembled structure looks like the one given in the below given image.



Fig. 1 Metallic Arc Welded Gear

**Drilling of the Chassis Rod.** In order to carry the viper motor, the rod joining the axle with the lower base of the wheelchair has to be drilled out. The drilling action enabled the rod to have a nut-bolt (M3\*12mm) to go through it and henceforth it was able to carry the motor with it as shown in the image. The drilling was done on the Vertical Drilling Machine. The chassis was firstly de-assembled and then later it was placed in the VDM and the drilling was done.



Fig. 2 Viper Motor fitted in the chassis rod by drilling out the chassis rod and passing a nut-bolt (M3\*12 mm)

The drilling process was also done on the other side as well, this was done in order to make it suitable for carrying the batteries. For this, firstly a L-shaped structure was fabricated out of iron plates and then it was incorporated with the chassis by using nut and bolt.

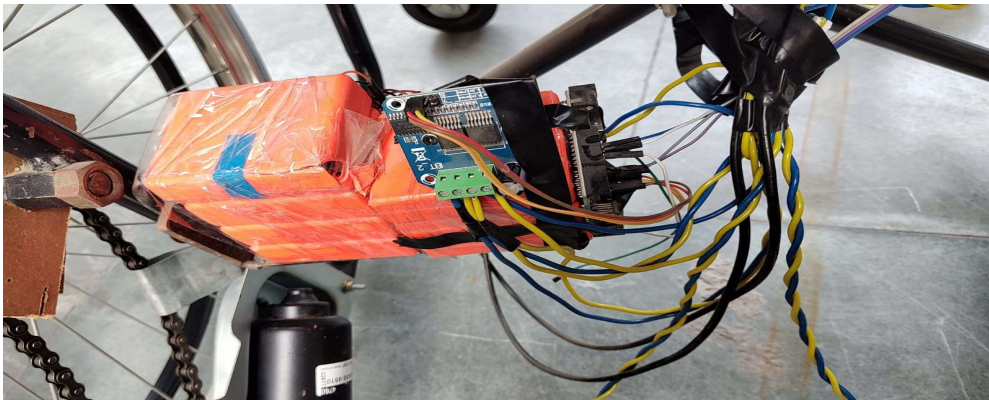

Fig. 3 Battery section held by the L-shaped iron plate

**Alignment.** The transfer of power within the mechanical system under investigation occurs from the motor to a gear affixed to its rotor, subsequently conveyed to another gear via a speed-chain mechanism. Given the spatial separation between the driving and driven axes, and the utilization of a chain drive for power transmission, precise alignment of these axes assumes paramount significance. Failure to achieve optimal alignment results not only in diminished power transmission efficiency but also exacerbates the likelihood of chain disengagement from gear teeth, particularly under heightened operational velocities, attributable to the imposition of axial forces. The aligned system is shown in the fig. 4



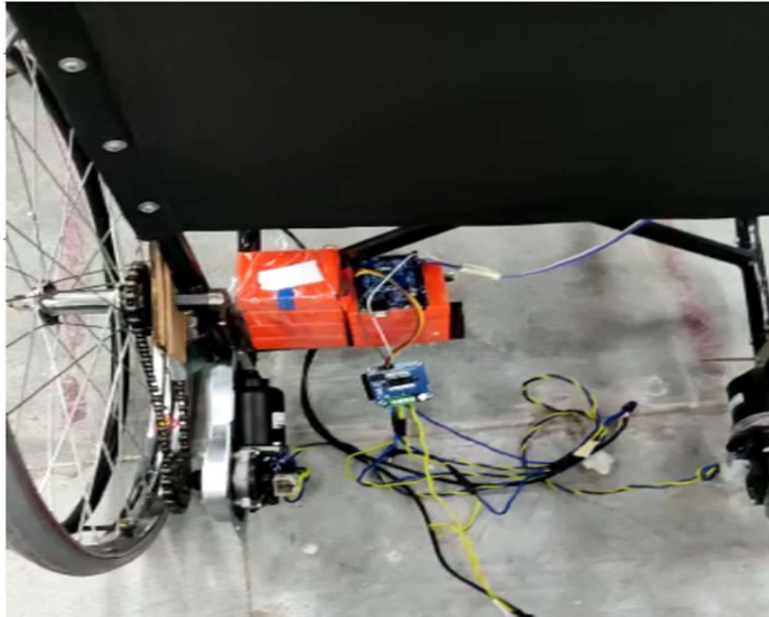

Fig. 4 Driver and driven axis are vertically aligned.

**Flow of Command.** In a hand-gesture driven wheelchair, the flow of command revolves around intuitive hand movements to control the movement and direction of the wheelchair. This innovative technology enables individuals with limited mobility to navigate their environment with greater independence and ease. The flow of command typically involves several key steps:

1. **Gesture Recognition:** The system begins with capturing and interpreting hand gestures made by the user. Advanced sensors and cameras detect and analyse the movements of the user's hands in real-time. This is done by an RF module, known as Accelerometer sensor. This sensor sense the movement of the palm of the user by scaling it on an x-y-z 3D plane.
2. **Mapping Gestures to Commands:** Once the gestures are recognised, they are mapped to specific commands that dictate the movement and direction of the wheelchair. For example, a forward hand movement might correspond to moving the wheelchair forward, while a sideways movement could signify turning left or right. This is done when the information received from the accelerometer sensor is sent to the Arduino UNO. Arduino UNO is capable of interpreting this information and thus evaluated the direction in which it has to turn the wheelchair.
3. **Command Execution:** Upon recognising the gestures and translating them into commands, the wheelchair's on board Arduino system executes the corresponding actions. This involves controlling the wheelchair's motors and wheels to move in the desired direction and at the desired speed. This action is controlled by the motor controller of the circuit, which directs the motor to move the wheelchair accordingly.

4. Driving of the wheels: Once the motor controller interprets the information received from the Arduino, it transmits the process flow to the motors. Motors being powered by an external; battery reads the signals and henceforth drives the wheelchair by providing enough power and torque to the wheels of the chair and making it move swiftly.

Overall, the flow of command in a hand-gesture driven wheelchair prioritizes simplicity, responsiveness, and user-friendliness, empowering individuals with mobility impairments to navigate their surroundings with confidence and autonomy. This flow process is depicted in the fig.5.

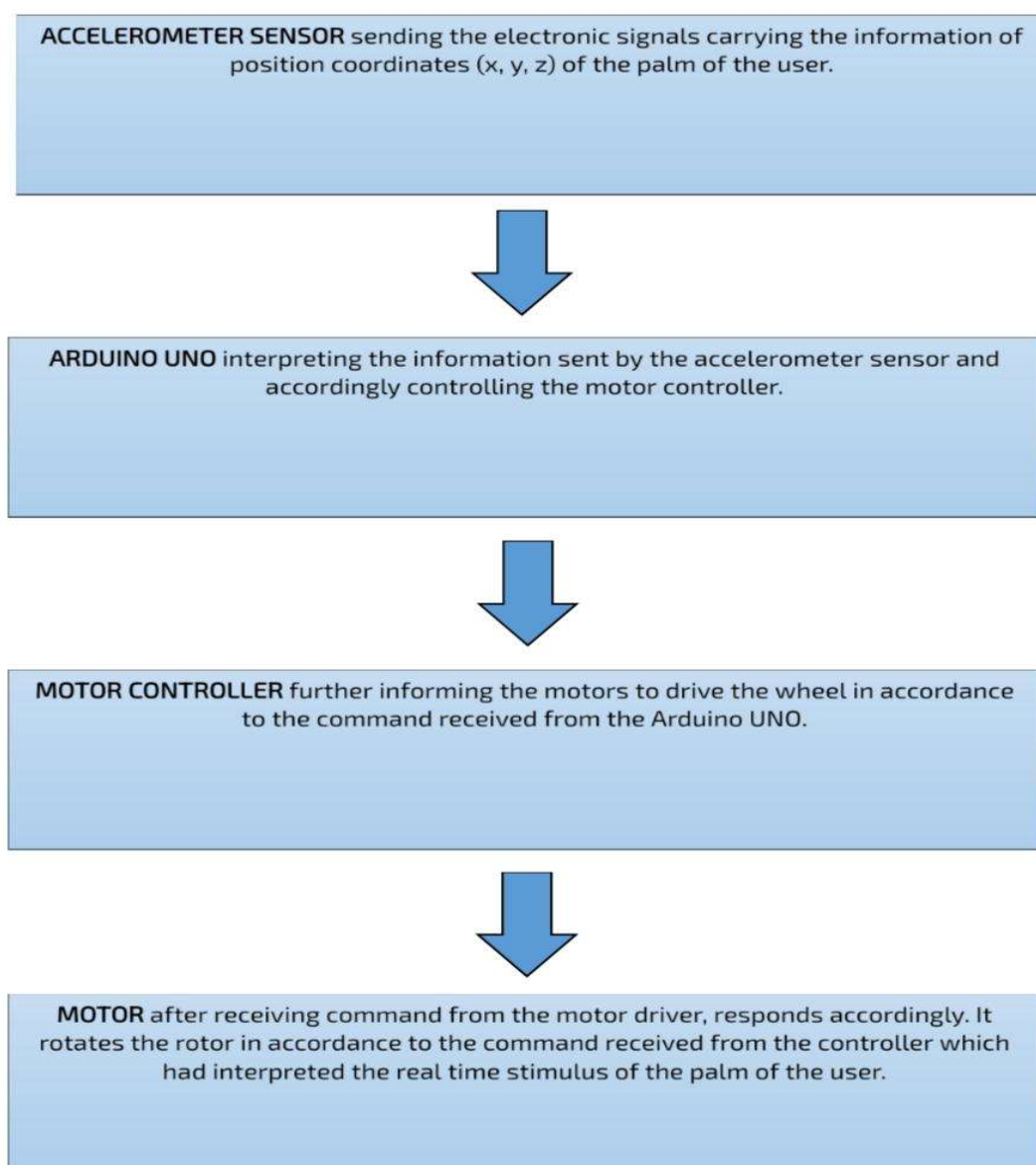

Fig 5. Flow of Command

**Description of Components.** A wheelchair controlled by hand gestures integrates several key components to enable seamless interaction. Firstly, the gesture recognition module employs sensors, like accelerometers, to interpret hand movements. These sensors detect gestures such as tilting, swiping, or waving, translating them into commands for the wheelchair. Connected to this module is a microcontroller unit (MCU) responsible for processing the gestures and triggering appropriate actions. The MCU communicates with motor controllers to regulate the wheelchair's movement, including speed and direction. Power management components, like batteries and charging circuits, ensure uninterrupted operation. Finally, ergonomic design considerations ensure user comfort and ease of interaction. Together, these components create an intuitive and efficient interface between the user's hand gestures and the wheelchair's control system, enhancing mobility and independence for users with mobility impairments. The detailed discussion of these components is done in the section given below:

1. **Arduino Uno.** The Arduino Uno board is a popular microcontroller board based on the ATmega328P microcontroller chip. It features digital and analog input/output pins that can be used to connect various sensors, actuators, and other components. The board also includes a USB connection for programming and power, as well as a power jack, reset button, and an ICSP header for advanced programming.

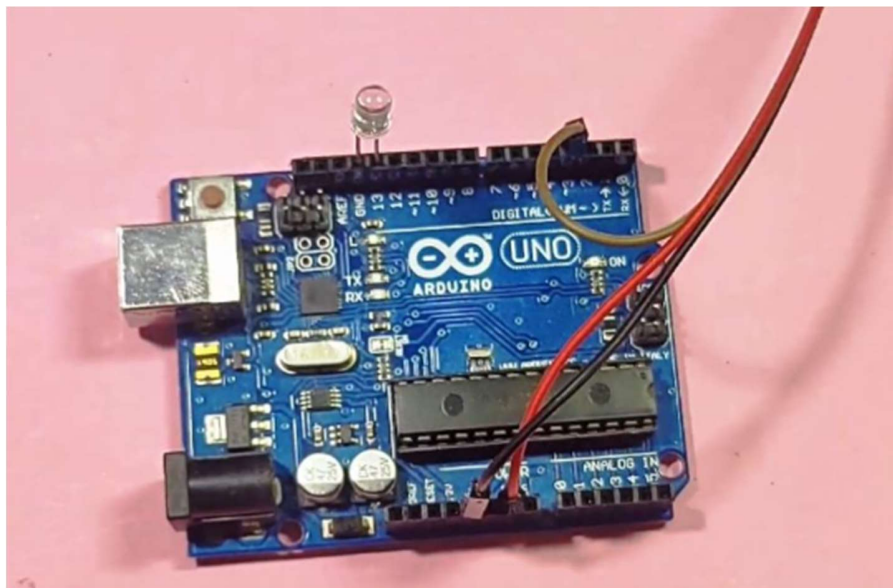

Fig. 6 Arduino UNO used in the project

2. **Motor Controller.** Motor controller basics are like the conductors orchestrating the dance of motors in the electronic realm, turning the wheels of motion with precision and control. Imagine them as the maestros, directing the symphony of electrical signals to ensure motors move harmoniously in response to our commands. Motor controller provides 8 pins as shown in the figure. Two pins are of VCC and GND, one for each. Two pins labelled as R\_IS and L\_IS are for controlling one of the motor. These pins take the information from the Arduino board in the form of 0 and 1. If both the pins gets the potential difference in their command then the motor controller will drive the motor. The same goes for R\_GN and L\_GN, they are liable to control the other motor. The last pair of pins named as R\_PWM and L\_PWM are for the purpose of modulating the pulse width. It is used to regulate the speed of a motor by controlling the amount of power delivered to it.



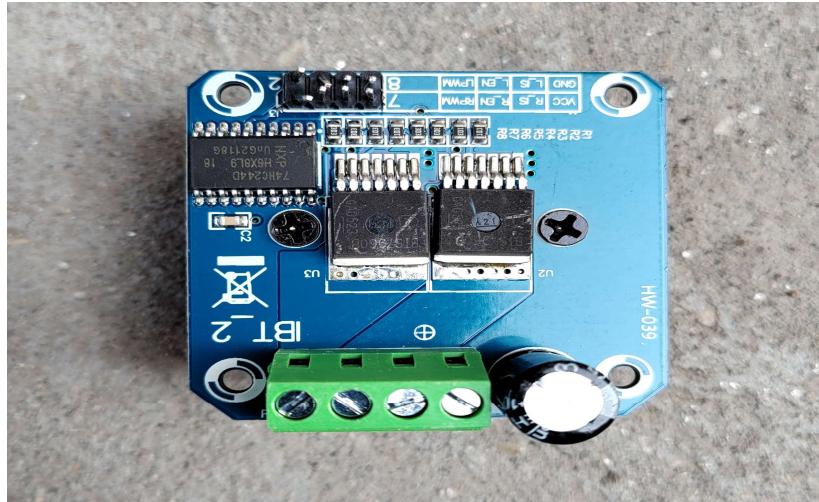

Fig.7 Motor Controller (74HC244D)

3. **Dc Motor (14 W, 12v).** A DC motor controller is the maestro in charge of directing the speed and direction of a DC (Direct Current) motor. Think of it as the conductor orchestrating the performance of a motor in an electronic symphony. The primary function of a DC motor controller is to regulate the flow of electrical current to the motor, determining its rotational speed and controlling its movement. These controllers utilize various techniques to achieve precise motor control. One common method is Pulse Width Modulation (PWM), which involves rapidly switching the power on and off. By adjusting the width of the pulses, the average power reaching the motor changes, effectively controlling its speed. Additionally, DC motor controllers often feature functionalities such as reversing the motor's direction, braking, and current limiting. This versatility makes them crucial in applications ranging from robotics and automation to hobbyist projects.



Fig. 8 DC Viper Motor (14W, 12V)

4. **Accelerometer Sensor.** Accelerometer sensors serve as integral components within hand gesture-controlled wheelchairs due to their ability to accurately detect and interpret motion-based inputs. These sensors are pivotal in facilitating seamless interaction between the user and the wheelchair, enabling precise and responsive control mechanisms. Moreover, accelerometer sensors contribute to the development of robust

and adaptive control algorithms tailored to accommodate diverse user preferences and mobility requirements. Furthermore, the integration of accelerometer sensors enables the implementation of sophisticated gesture recognition algorithms, capable of discerning subtle variations in hand movements.

In summary, the incorporation of accelerometer sensors in hand gesture-controlled wheelchairs represents a pivotal advancement in assistive technology, empowering users with enhanced mobility and autonomy. Through their ability to accurately detect and interpret hand gestures, accelerometer sensors facilitate intuitive interaction with the wheelchair, while also enabling the development of adaptive control mechanisms tailored to individual user needs. This integration exemplifies the convergence of cutting-edge sensor technology and assistive robotics, with profound implications for improving the quality of life and independence of individuals with mobility impairments.

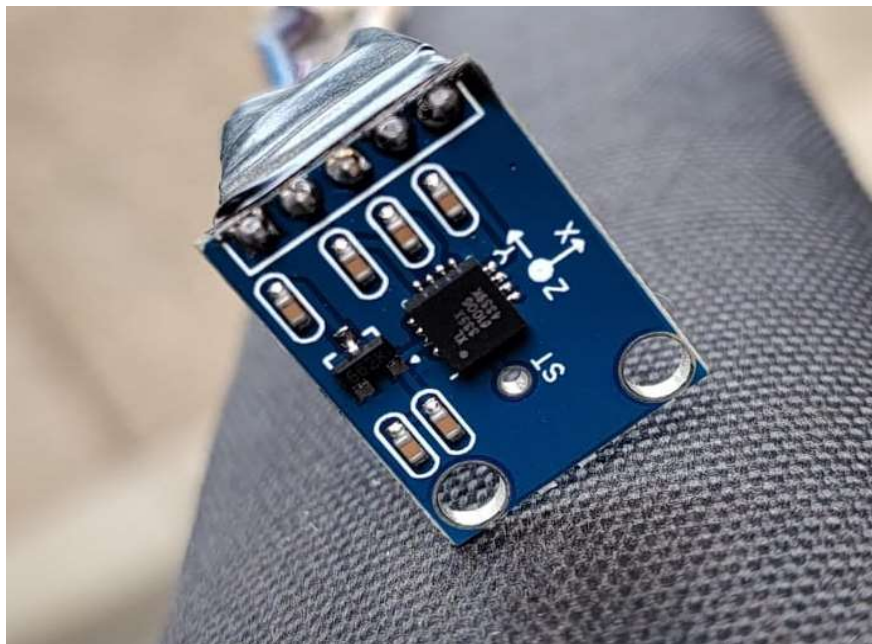

Fig. 9 Accelerometer Sensor (Adxl 1345)

- 5. Dc Battery (12v).** A DC battery is preferred in a hand gesture-controlled wheelchair due to its inherent characteristics that align with the requirements of the system. Firstly, DC batteries offer portability and compactness, crucial for a wheelchair design focused on user mobility. Additionally, they provide a stable and reliable power source, ensuring consistent performance during prolonged usage. Moreover, DC batteries can be recharged efficiently, offering convenience and sustainability in operation. Furthermore, their electrical properties allow for seamless integration with motor control systems, facilitating precise and responsive hand gesture control. Thus, the utilization of a DC battery enhances the functionality and usability of hand gesture-controlled wheelchairs.

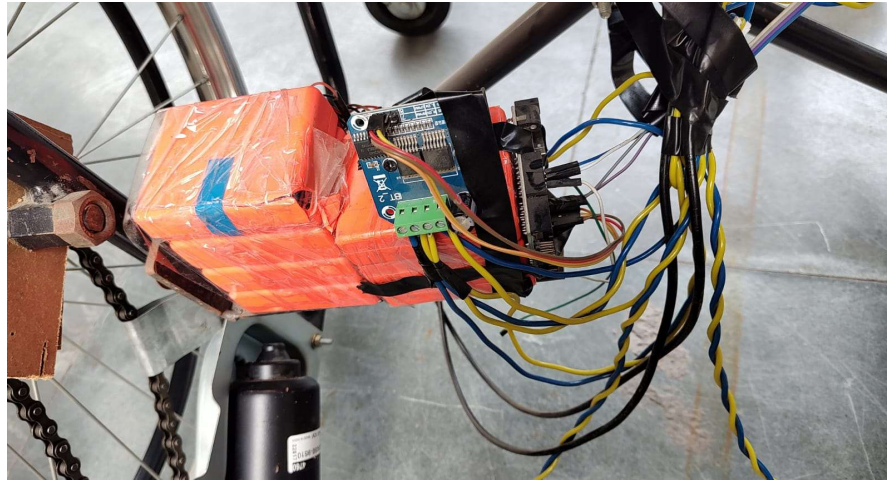

Fig. 10 Parallel connection of 6 cells (12V)

**Circuit Analysis.** Complex circuit of the wheelchair can get simplified by studying it element by element. So, overall the circuit consist up of the given below elements:

1. Motor controller circuit
2. RF module circuit
3. Battery and Arduino

On combining these three individual circuits, one can create a new circuit that would be able to drive the wheelchair in forward, backward or left and right directions. So, we will now deep dive into the above given circuit elements one-by-one and will try to understand the significance of their connections.

### 1. Motor Controller Circuit

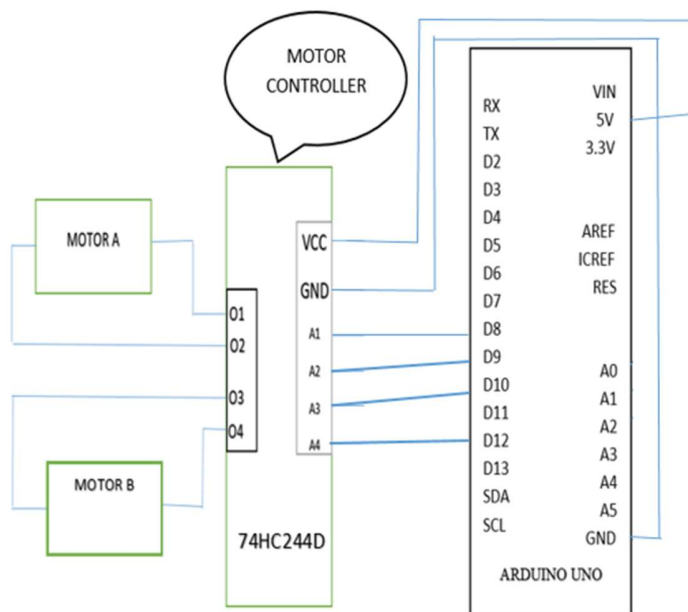

Fig. 11 Circuit diagram of Motor Controller connected with Arduino Uno

The motors are connected with the motor driver (74HC244D) through the jumper wires in the output terminals of the driver. Then the driver is connected with the Arduino UNO board by making given below connections:

1. VCC of the driver to the VCC/VIN/5V of the board.
2. GND of the driver to the GND/0V of the board.
3. Two input pins of the driver (here A1 & A2) to the two of the digital pins of the board and other two (A3 & A4) with the other two digital pins of the board.

These connections ensures the working of the motor drivers which eventually controls the motors that drives the wheels of the chair. The output terminals ensures the connection of the motors with the driver and also decides the polarity of the motors. By connecting VCC to 5V and GND to 0V, it is made sure that the driver gets aligned with the Arduino board. The input pins controls the driving action of the motors, if the digital pins of the board gives the input pins a potential difference then the motor will rotate its rotor, otherwise it will remain in the idle condition.

### 1. RF MODULE CIRCUIT

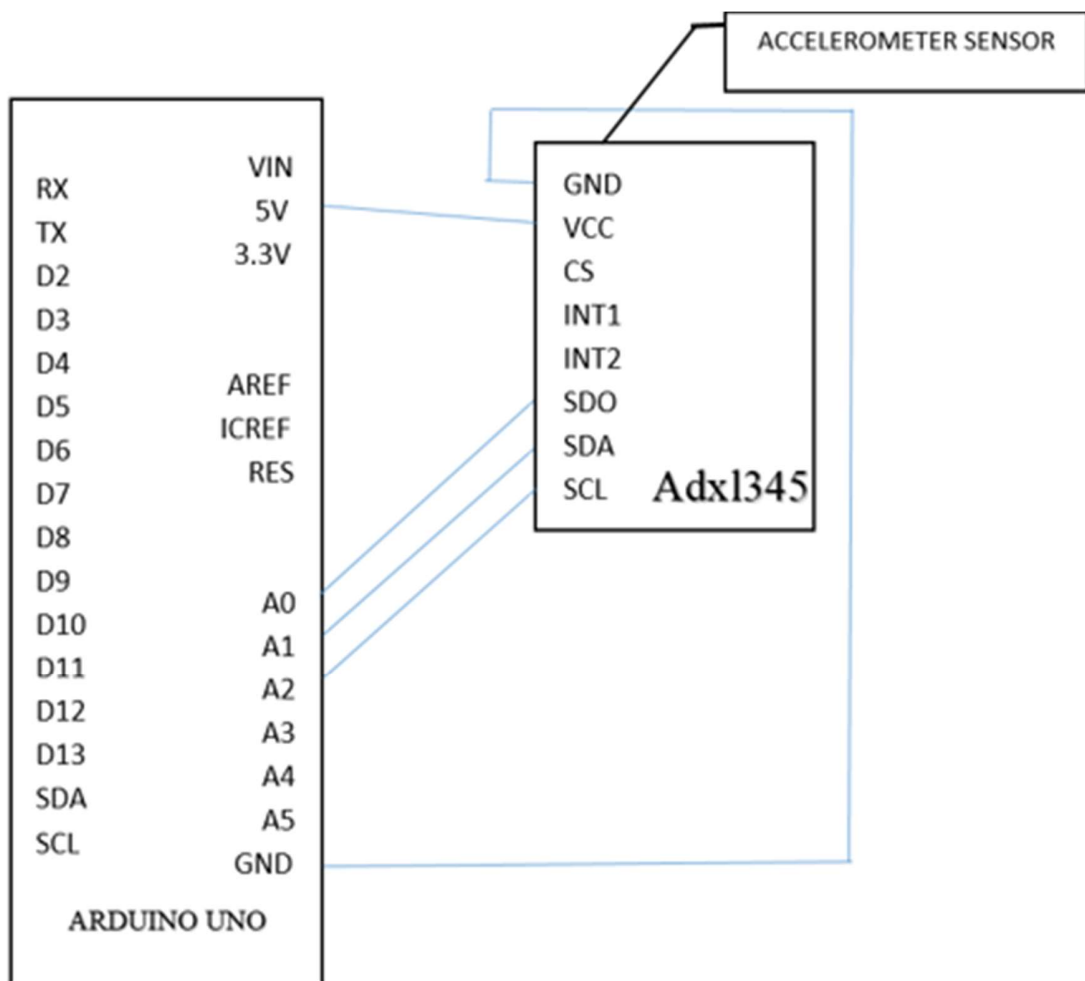

Fig. 12 Circuit analysis of Accelerometer sensor

The Accelerometer sensors has three axis control in it which is diagrammatically represented through SDO, SDA, and SCL pins on the sensor. These are connected to the Arduino board in the Analog pins through jumper wires. The sensor gets its potential difference through VCC and GND connections of the sensor with the board. Through this connection, the RF sensor starts giving its axial coordinate locations to the board through the analog pins, using which we can eventually set the reference for the hand glove and parameters for the chair through which it will move in various directions.

## 2. ARDUINO AND BATTERY CIRCUIT

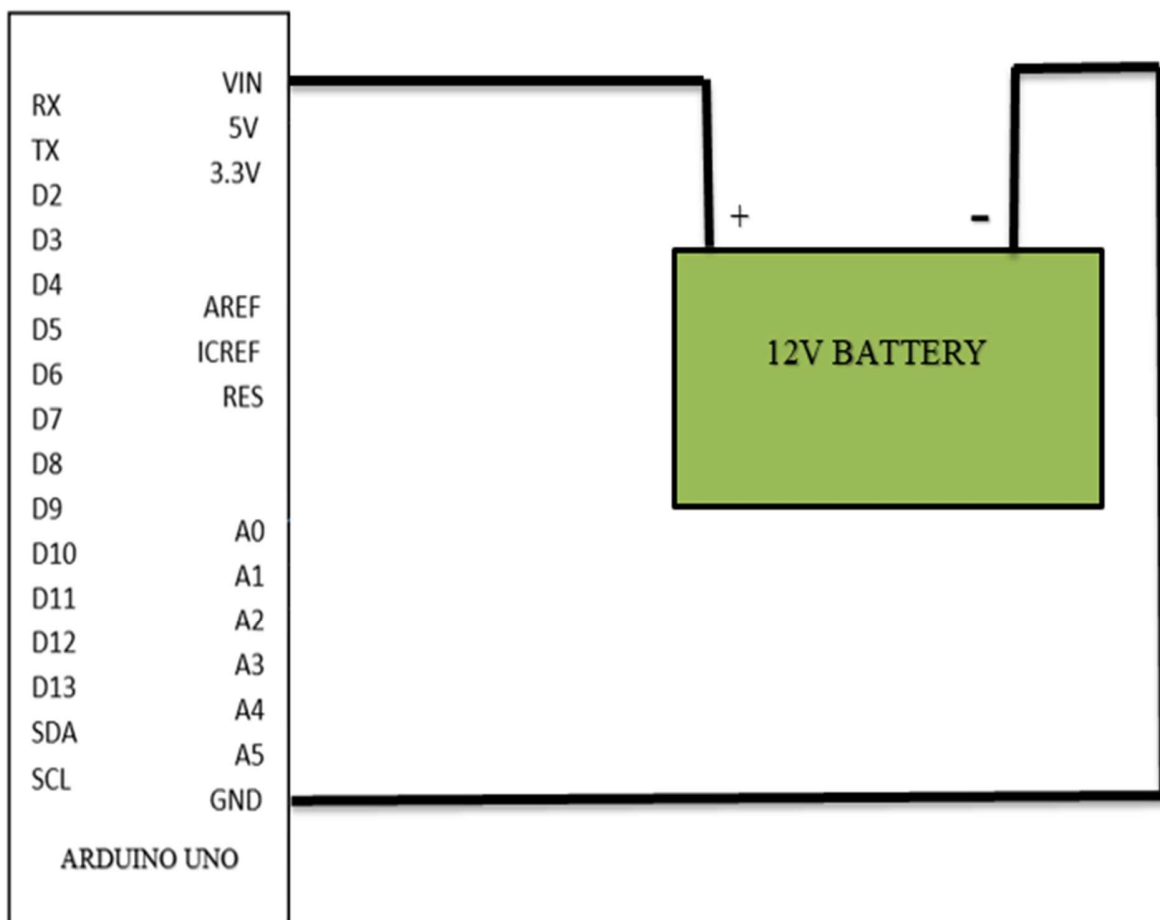

Fig. 13 External Connection of Arduino with a power source (12V DC battery)

The external battery is connected to the circuit so that it could power the circuit in the absence of the system connection. This battery further helps in providing sufficient power that could help the motor to produce the torque that could turn the wheels of the wheelchair.

**Conclusion.** The research presented underscores the significant strides made in developing hand-gesture controlled wheelchairs as a promising alternative to traditional joystick-controlled models. Through meticulous mechanical adaptations and integration of electronic components, these wheelchairs offer enhanced manoeuvrability and accessibility for individuals with mobility



impairments. Moreover, the study highlights the importance of balancing cost-effectiveness with strict standards of material quality and operational performance in wheelchair design. By leveraging advancements in sensor technology, gesture recognition algorithms, and motor control systems, researchers have successfully created intuitive and efficient interfaces that empower users with enhanced mobility and autonomy. Moving forward, further research and development in this field should focus on addressing remaining challenges such as power dependency, device failure, and cost barriers associated with adoption. Additionally, continued collaboration between researchers, engineers, healthcare professionals, and end-users is essential to ensure that hand-gesture controlled wheelchairs meet the diverse needs of individuals with mobility impairments, ultimately improving their quality of life and independence.



Fig. 14 Final prototype: Fully assembled wheelchair capable of being operated solely through hand gestures.

### References

- [1] P. Upender P, Harsha Vardhini (2020), A Hand Gesture Based Wheelchair for Physically Handicapped Person with Emergency Alert System Proceedings - 5th IEEE International Conference on Recent Trends in Electronics, Info...
- [2] Tao Lu (2013), A Motion Control Method of Intelligent Wheelchair Based on Hand Gesture Recognition, Proceedings of the 2013 IEEE 8th Conference on Industrial Electronics and Applications (ICIEA)

- [3] Prof. Vishal V. Pande, N Nikita S.Ubale, Darshana P. Masurkar, Nikita R. Ingole, Pragati P. Mane (2014), Hand Gesture Based Wheelchair Movement Control for Disabled Person Using MEMS. *Int. Journal of Engineering Research and Applications* www.ijera.com ISSN: 2248-9622, Vol. 4, Issue 4(Version 4), April 2014, pp.152-158
- [4] Ramessur, S.A., Oree, V. (2019). Hand Gesture Controller for Robotic-Wheelchair Using Microelectromechanical Sensor ADXL 345. *Smart and Sustainable Engineering for Next Generation Applications. ELECOM 2018. Lecture Notes in Electrical Engineering*, vol 561. Springer, Cham.
- [5] Goyal D, Saini S (2013), Accelerometer Based Hand Gesture Controlled Wheelchair, *International Journal on Emerging Technologies* 4(2) 15-20
- [6] Mahmood, M., Rizwan, M.F., Sultana, M., Habib, M.A., & Imam, M.H. (2020). Design of a low-cost Hand Gesture Controlled Automated Wheelchair. *2020 IEEE Region 10 Symposium (TENSymp)*, 1379-1382.
- [7] Rusydi, M.I., Afmi, Y., Sari, R., Jordan, A., Rahmadani, F., Nugroho, H., & Setiawan, A.W. (2023). Hand Gesture Wheelchair Control Based on the Wrist Rotation with Agglomerative Hierarchical Clustering Method. *2023 8th Asia-Pacific Conference on Intelligent Robot Systems (ACIRS)*, 95-99.
- [8] Patankar, N.S., Shaharam, D.A., Rajendra, D.T., Bhausheb, G.S., Satish, P.S., & Deshmukh, Y.S. (2023). IoT Based Hand Gesture Control Wheelchair for Disabled Person. *2023 4th International Conference on Smart Electronics and Communication (ICOSEC)*, 346-352.
- [9] V Sundara Siva Kumar, G.Ramesh and P Nagesh,” MEMS based Hand Gesture Wheel Chair Movement Control for Disable Persons” *International Journal of Current Engineering and Technology*. May 2015. 3. Pushpendra Jha, and Preeti Khurana, “Hand Gesture Controlled Wheelchair”, *IJCTA*.
- [10] John, F., Shaju, J., Mathai, M. K., & Seby, M. (2019). Gesture controlled wheelchair. *Journal of Embedded Systems and Processing*. Retrieved March 17, 2024, from <http://matjournals.in/index.php/JoESP/article/view/4419>.
- [11] Megalingam, R. K., Sreekanth, S., A, G., Teja, C. R., & Raj, A. (2017, January). Wireless gesturecontrolled wheelchair. *IEEE Xplore*.
- [12] Bourhis, G., Moumen, K., Pino, P., Rohmer, S., & Pruski, A. (2002). Assisted navigation for a powered wheelchair. *IEEE Xplore*.