



Energy Conserving Economical Automated Smart Control System for Street Lighting

N.D.G.T. Nanayakkara and L.G.P.K. Guruge

EasyChair preprints are intended for rapid dissemination of research results and are integrated with the rest of EasyChair.

May 26, 2021

ENERGY CONSERVING ECONOMICAL AUTOMATED SMART CONTROL SYSTEM FOR STREET LIGHTING

Nanayakkara NDGT^{1*} and Guruge LGPK²

¹Sri Lanka Electrical and Mechanical Engineers Regimental Centre, Army Camp, Colombo 02, Sri Lanka

²Department of Computer Systems engineering, University of Kelaniya, Sri Lanka

*thatsarananayakkara@gmail.com

Abstract— In Sri Lanka, there exist several types of street lighting systems. There are switches fixed to the street light poles that are situated along the roads, usually, people neglect to switch off and wasting energy during the day. A set of street lights with a single switch to turn on and off is another type and this system requires additional wiring for controlling. The street lights that are connected to a photodiode operates according to the sunlight level another type of street lighting and that cannot be operated remotely as it automatically turns the lights on and off. Thus, a massive amount of energy is wasted. The street light system of wireless operated also not suitable for street lights in countries such as ours, because the wireless automation unit cost is high. Hence it is conclusive that in Sri Lanka, a smart control system for street lighting is a necessity. This research scrutinizes the feasibility of an economical automated system for the street lights which subsequently will reduce power wastage and increase efficiency. By using the planned system, every light can be controlled whenever needed, without additional cost for wiring to control the lights and switches for every pole. For the experiment, home electrical system automation protocol X-10 has been selected as the power line communication protocol. With the proposed system, the control signal can be sent over the power lines instead of the requirement of wiring another line for controlling is advantageous than wired and wireless systems. Fixing the implemented receiver unit for every light is sufficient. The cost of the receiver unit also will be less compared to the existing systems and the cost of energy wastage.

Keywords: X-10 protocol, Communication protocol, energy conservation

I. INTRODUCTION

There are several reasons to use an automated system for Street lights. The main reason would be to reduce the waste of power. Wastage of power through the street light system of Sri Lanka is a huge problem that is faced by the country. Present time the street lights in a

particular area are controlled by the respective municipal council. As we go along a road, we can see that most of the street lights are on during the daytime where there isn't any requirement. Implementation of this control system will result in saving a substantial amount of energy as well as man-hours utilized for control purposes.

Decreased overhead cost is an important factor. The pertaining street light system of Sri Lanka is underdeveloped in relevance to modern-day technology. In some parts of the country, a cluster of street lights is controlled by a single wire placed along with power lines. If this wire is provided individually, the cost for wiring will increase.

The smart control system of light system is essential. In a normal Sri Lankan wired street light system every bulb can't be controlled individually. In some instances, some roads do not need every bulb. Using an automated system, we can turn on only required bulbs and switch off others to save energy. Now with the development in urban areas, most of the street lights are connected to a photodiode which will operate according to the daylight level. These cannot be operated remotely but they will automatically turn the light on and off. But using the smart control system we can control every light whenever we want.

There are some types of street light control systems such as Wireless, Wired. X-10 is a home automated system and is the method that we selected to control the street light system in Sri Lanka. In wired automation wire cost is high. In wireless automation GSM Unit cost is high and Wi-Fi is not available in every place. Wireless is also not suitable for some countries such as ours. But wireless is more advantageous than wired simply due to the absence of wires. Even though in this power line communication system there are advantages over both wired and wireless.

The planed system discussed here provides an answer for high energy consumption. In this era, humans have become restless and are not in a position to regulate manual operations in any field. Hence, rapid advancement in embedded systems had a paved path for the virtual mechanisms based on microcontrollers. This research presents an automatic street light controller using power line communication Protocol.

Through the smart control system, we can send a signal over power lines. In this method, there is no requirement of wiring another line for controlling. Fixing a

control unit to each light will enable us to control them separately. We can control bulbs in a particular place without the need for any wirings. We can send a signal through current lines without any wiring cost. The cost of that prepared unit falls under an acceptable margin in comparison to the wire cost and electricity wastage.

II. OBJECTIVES

Automation is the primary concern in present field technologies. Then comes the question of power consumption and cost-effectiveness. Automation is meant to scale back the use of the workforce with the assistance of intelligence systems. The main aim of this project is to design an x-10 automated module for controlling street lights. Therefore villages, towns we can style intelligent systems for the usage of streetlights.

III. HOW DOES IT USE

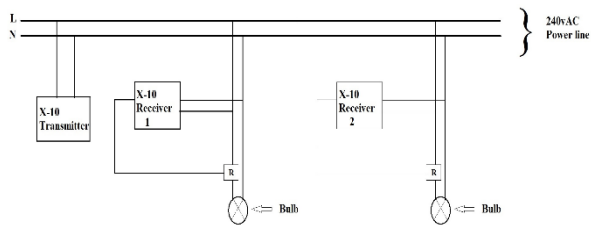

Figure 1. Basic block diagram

This is the basic idea of my project. Form the planed system x-10 transmitter is connected through the power lines. The transmitter consists of the zero-crossing detector and 120 kHz signal generator. The signal is sent to AC power lines by the transmitter. The signal sent to the AC power line is detected by receiving circuit According to the given command can be light on-off and control the lights.

IV. EXCITING RESEARCH

A. Zero-Crossing Detector

In X-10, information is timed with the zero-crossings of the AC power. A zero-crossing detector is easily created by using the external interrupt on the RB0 pin and just one external component, a resistor, to limit the current into the PICmicro.

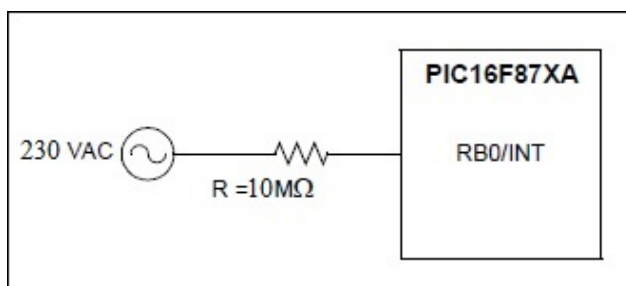

Figure 2. Zero Crossing Detector

$V_{rms} = 230 \text{ VAC}$, and the peak line voltage is 325V . If we select a resistor of $10 \text{ M}\Omega$, $I_{peak} = 325/10 \text{ M}\Omega = 32.5 \mu\text{A}$

B. Transmitter

In the transmitter module, there are zero-crossing detectors and 120 kHz signal generator.

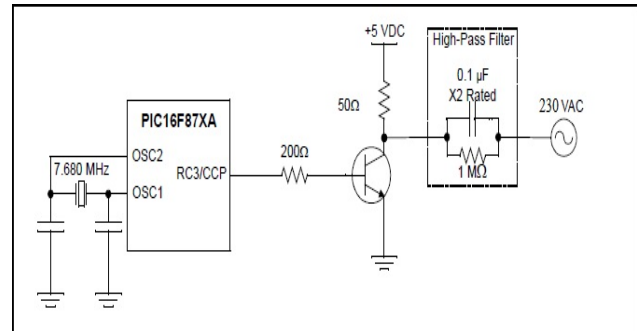

Figure 3. 120 kHz Carrier Generator

120 kHz signal will generate from the Microcontroller and signals send through the transistor to power it. We required a high-frequency signal, from the High Pass filter only High-frequency signals are sent to other blocks. Signals that come from high pass filters send to the AC power line.

X-10 uses 120 kHz modulation to transmit information over 60 Hz power lines. It is possible to generate the 120 kHz carrier with an external oscillator circuit. A single I/O pin would be used to enable or disable the oscillator circuit output. However, an external oscillator circuit can be avoided by using one of the PIC micro modules.

C. Receiver

In the receiver module, there are a zero-crossing detector and a 120 kHz carrier detector.

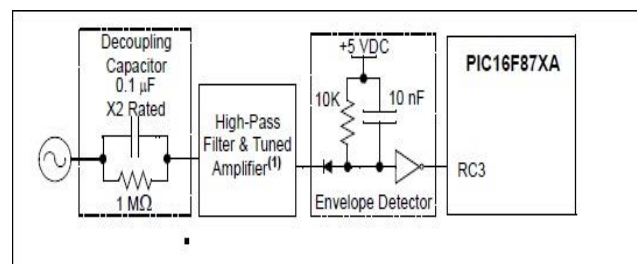

Figure 4. 120 kHz Carrier detector

This carrier detector is accomplished with a decoupling capacitor, a high-pass filter, a tuned amplifier, and an envelope detector. The components of the carrier detector are illustrated.

To receive X-10 signals, it is necessary to detect the presence of the 120 kHz signal on the AC power line.

A decoupling capacitor is used to reduce the effect of noise caused by the other circuit. From the envelope, the detector is an electronic circuit that takes a high-frequency

signal as input, and the capacitor in the circuit stores upcharge on the rising edge.

After that signal decodes from the PIC and takes the information that we need.

D. Protocol that using

For this single transmission, I used a very simple protocol.

- Four-bit for start code
- Eight-bit for Light address
- Four-bit for command

This is the overview of this protocol.

Example:

“1010 11010101 1001”.

In this example light address is 8bit one. Therefore we can control nearly 28 lights using that protocol. If we want to change no of bulbs that we control we can change it.

V. FURTHER DEVELOPMENT SIDE OF PROJECT

Using this x-10 system we can turn off not required bulbs. It is very useful to method as power saving just like over country. Control the opacity of bulbs in non-required areas is also we can implemented through this project. But the problem is if we use that project in practical it required to change over SriLankan bulbs to LED bulbs because normally srilankan using street lights can't control opacities. If we can change srilankan bulbs to LED bulbs from that also we can save energy.

VI. METHODOLOGY

Searched through the internet, books, articles, and find the information about previous researches, projects, etc. And also got some ideas from the supervisor about selecting a topic, how this information extends, and what are the area must cover through research.

VII. CONCLUSION

The main aim of the project is to save the power, by using effectively we can save more power, as we know there is a shortage of power. So to overcome that we can provide streetlights using an x-10 automated system. Using x-10 automated system we can control the streetlights, switching on street lights only required times and switch on less no of bulbs that lights not required areas and can save more power as well as save the cost of controlling wiring cable. So in the future, we can design many more advanced technologies to save power.

This paper explained how to use x-10 automation for street light systems. How we design the Transmitter, Receiver, and how we send the frequency over 230Vac line.

Finally, this control circuit can be used in long roadways between the cities. Here we are saving a lot of power and cost of wiring.

VIII. FURTHER RESEARCH

Using this x-10 system we can turn off not required bulbs. It is very useful to the method as power-saving just like over country. Control the opacity of bulbs in non-required areas is also we can implement through this project. But the problem is if we use that project in practice it is required to change over SriLankan bulbs to LED bulbs because normally SriLankan using street lights can't control opacities. If we can change Srilankan bulbs to LED bulbs from that also we can save energy.

REFERENCES

BusBk.com (Business-Bankruptcies.com), Washington Western Bankruptcy Court: Case Number 2:13-bk-17073, Bankruptcy filing for X10 Wireless Technology Inc. (2 August 2013). Retrieved 9 September 2013.

Jeff Dorsch (2005). "X10 Wireless Technology, Inc. company information". Hoover's.

"Electric lighting". ncl.ac.uk. Retrieved 2014-06-03

Brons, J. A.; J. D. Bullough & M. S. Rea (2008). "Outdoor site-lighting performance: A comprehensive and quantitative framework for assessing light pollution". *Lighting Research and Technology*. p. 40(3): 201–224.

<http://automation.hmtech.info/onetwoway.php> One way vs Two way retrieved 2011 Nov 6

Rye, Dave (October 1999). "My Life at X10". *AV and Automation Industry eMagazine*. AV and Automation Industry eMagazine. Retrieved October 8, 2014.

Rye, Dave (October 1999). "My Life at X10". *AV and Automation Industry eMagazine*. AV and Automation Industry eMagazine. Retrieved October 8, 2014.

Home automation newsgroup on Usenet (alternative free web access using Google Groups

How X10 works A detailed explanation of the X10 protocol.

X10 Modifications The original repository of X-10 schematics, modifications and X10 projects

X10 Knowledge Base A huge repository of trouble-shooting information for X10 projects. (Commercial site)